



# **Teaching God's Word**

**Oakwood Presbyterian Church**

**August 25, 2012**

# First, A Warning...

“Not many of you should become teachers, my brothers, for you know that we who teach will be judged with greater strictness. For we all stumble in many ways.”

James 3:1,2



# Aristotle: The Three Forms of Rhetoric

- **Logos** – appeal based upon logic, reason
- **Ethos** – appeal based upon character or reputation of the speaker
- **Pathos** – appeal based upon emotion

“Then Jesus said to the crowds and to his disciples, ‘The scribes and the Pharisees sit on Moses’ seat, so practice and observe whatever they tell you— but not what they do. For they preach, but do not practice.’”

Matthew 23:1,2



# Step #1: Prayer

- Jesus: “...without Me, you can do nothing.”  
John 15:5
- *for yourself*: for understanding and application of the passage and the ability to communicate effectively
- *for the group*: that their hearts would be prepared by the Spirit to receive the Word

“And it is my prayer that your love may abound more and more, with knowledge and all discernment, so that you may approve what is excellent, and so be pure and blameless for the day of Christ, filled with the fruit of righteousness that comes through Jesus Christ, to the glory and praise of God.”

Philippians 1:9-11



# Step #2 – Know the Passage

- Multiple readings to get familiar
- Read the context - neighboring verses, chapters, book
- Write down any unfamiliar words, names, or places
- Tools: Bible dictionary, a good study Bible, systematic theology
- Write down good observation questions – Who? What? Where? When? Why?

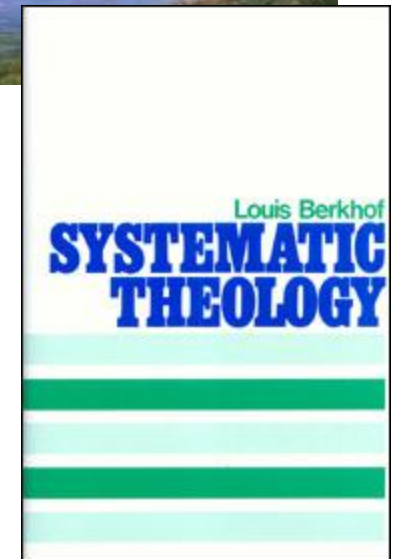
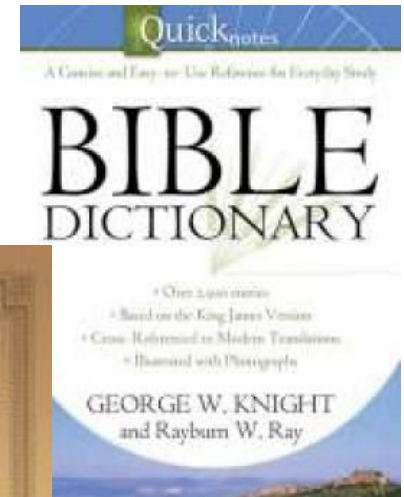
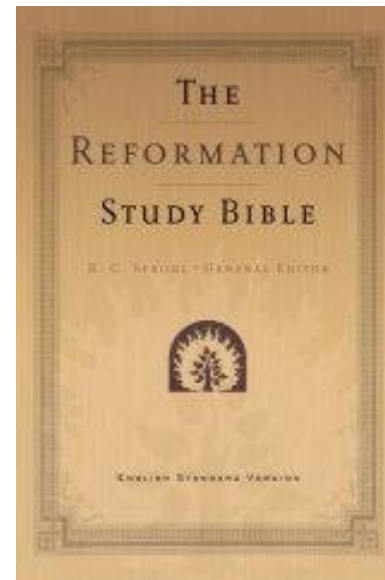

# Step #3 - Interpret the Passage

- Identify cultural issues - what did the author intend for the original readers to understand?
  - Example: Acts 15:28,29
- Know the type of writing - narrative, poetry, parable, apocalyptic literature, etc.
- Identify potential controversies - address or avoid?
- **IMPORTANT:** *Identify the main point* of the passage – your “target”
- Write down good interpretation questions



# Interpret Scripture by Scripture

- Westminster Confession of Faith, Chapter I, paragraph 9 – “The infallible rule of interpretation of Scripture is the Scripture itself: and therefore, when there is a question about the true and full sense of any Scripture...it must be searched and known by other places that speak more clearly.”
- Tools: Concordance, topical Bible, commentaries
- Be careful not to *over-use* parallel passages – use them to clarify and support

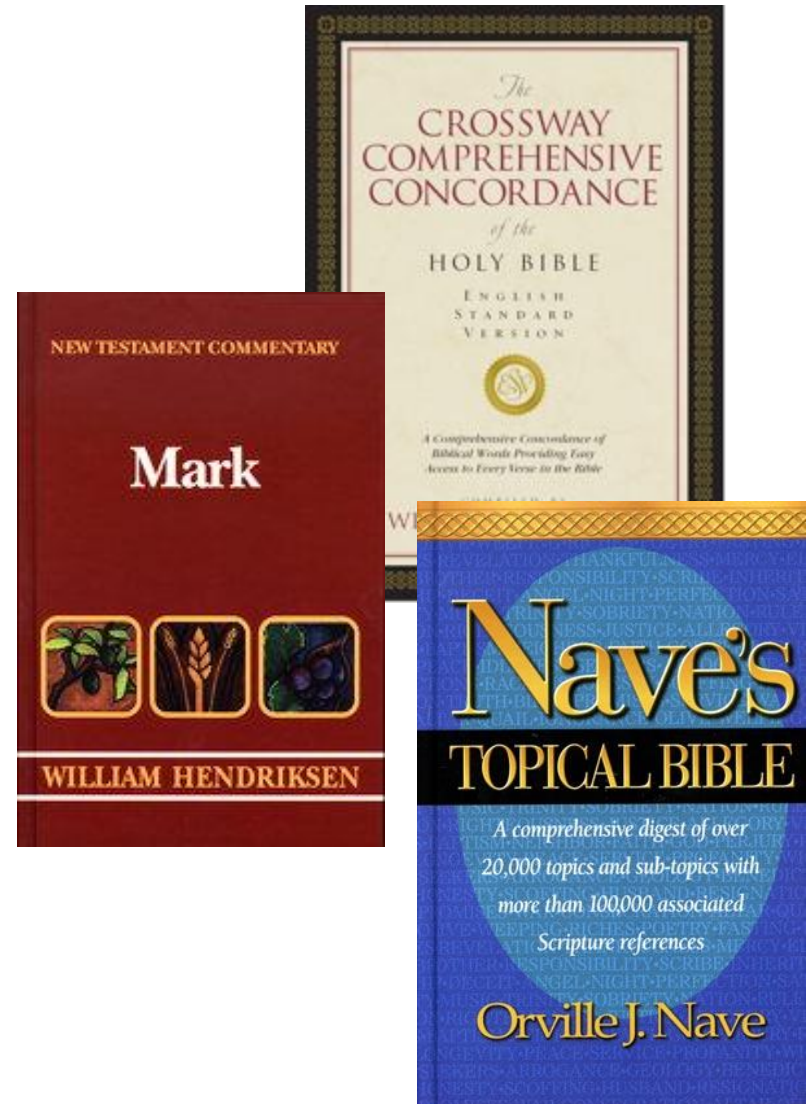

# Bible Software

PC Study Bible V5

File Tools Edit Options Window Online Help Interlinear Pane

Back Forward Bibles Concordance Topics Commentaries Greek/Hebrew Books Media Library Search Copy Clear Print

1 Peter 5:5 (Interlinear) 1 Peter 5:1 (ESV)

1 Peter 5:5

5 Ὅμοίως, BX Likewise, 3668 Homoíoois	νεώτεροι, JMPNCΞJMPVCΞ younger, 9999 3501 neóoteroi	ὑποτάγητε V2PAPM submit 5293 hupotágeete
	πρεσβυτέρους· NMPD yourselves 9999 presbutérouis	πάντες JMPNΧΞJMPVΧΞ all 3956 Pántes
	δὲ CCB be subject <9999> dé	ἀλλήλοις ORCMPD one to another, 1161 240 alleélois
ταπεινοφροσύνην NFSA humility: 5012 tapeinofrosúneen	ἐγκωμιάσασθε, V2PAMM and 9999 engkomboós	ὅτι CSC be clothed 1463 oti
[ὁ] θεός AMSN NMSN 3588 2316 Ho Theós	ὕπερηφάνους ἂν JMPDX the proud, 9999 5244 hupereefánois	
ταπεινοῖς JMPDX to the humble. 5011 tapeinois	δὲ CCV and 1161	δίδωσιν χάριν. V3SPAΙ NFSA giveth grace 1325 5485 dídoosin chárin

NT:3199 μέλω **melo** (mel'-o); a primary verb; to be of interest to, i.e. to concern (only third person singular present indicative used impersonally, it matters);  
KJV - (take) care.

NT:3200 μεμβράνα **membrana** (mem-bran'-ah); of Latin origin ("membrane"); a (written) sheep-skin;  
KJV - parchment.

NT:3201 μέμφομαι **memphomai** (mem'-fom-ah-ee); middle voice of an apparently primary verb; to blame;  
KJV - find fault.

simoiros  
a presumed  
moira (fate; akin to  
fate, i.e.

primary particle;  
properly, indicative of affirmation or  
concession (in fact); usually followed by a  
contrasted clause with NT:1161 (this one, the  
former, etc):

8 matches in Nelson's Bible Dictionary for "1 Peter 5:5"

Reference	Context
ELDER	of age (1 Tim 5:2 1 Peter 5:5).
ELDER	(1 Tim 5:17 1 Peter 5:5).
PETER, EPISTLE	question of trials (4:1-5:11). In
PETER, EPISTLE	the flock (5:1-11). The epistle



# Step #4: Application

*“The goal of interpretation is application.”*

- Based upon this passage, what does God want you to believe? What does God want you to do? *The Principles*
- To what situations in my life and my world do these Biblical principles apply?
- Apply to yourself first, then the group
- Write down good application questions



# The Bridge of Application



Biblical  
Culture

Exegesis

Knowledge of  
Culture

Modern  
Culture

# Step #5: Finalize & Then Answer Your Own Questions

- Don't rely exclusively on study guides
- Start with observation questions, then launching questions, then guiding questions

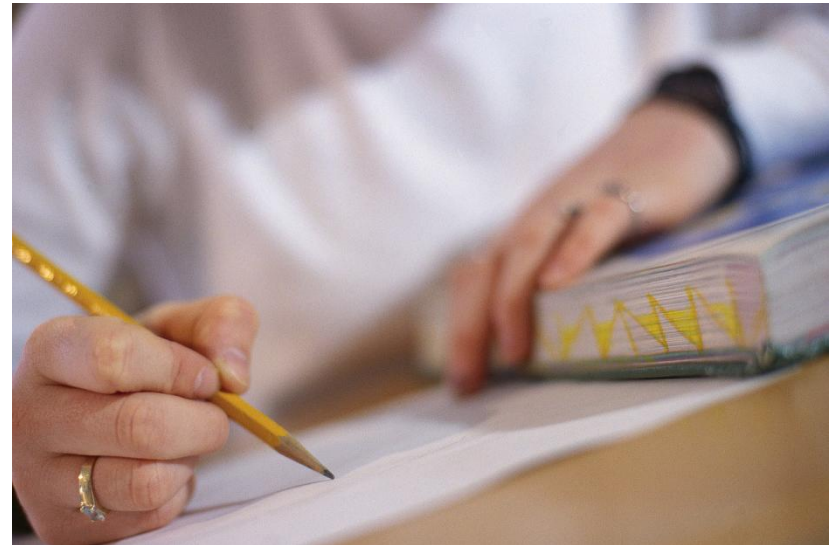

# Leading the Study – The Importance of Questions

- The Jesus Method (otherwise known as “the Socratic Method”)
  - “Who do people say that I am?”
- Purpose of questions:
  - To engage creativity and problem-solving
  - To make people think
  - To clarify terms
  - To challenge preconceptions
- Asking good questions – an *acquired* skill



# Breaking the Ice

- Casual Conversation
- Relationship Building
- “Priming the Pump”
- Introducing the Theme



# Observation Questions

- Begin with an overview – context, the main point of passage (target), relevance
- Observation questions are used to point out the important elements in the passage
- Who? What? Where? Why? When? How?



# Launching Questions



Getting the Discussion Going

# Characteristics of Good Launching Questions

- They have many right answers
- They have a suitable difficulty
- They focus attention on the target

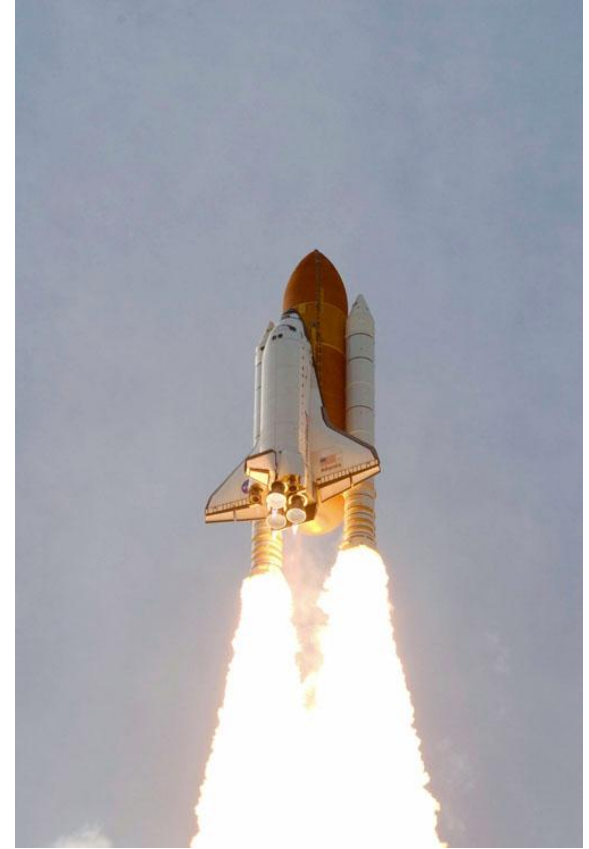



# Many Right or Valid Answers

- Bad question: “Are people created in God’s image?”
  - Rather, “What does it mean to be made in the image of God?”
- Bad question: “How much does God love us?”
  - Rather, “What are some ways in which God shows us that He loves us?”



# Suitable Difficulty

- Bad question: “What are some of the mysteries referred to in Scripture?”
  - Rather, “What are some questions that you would like to ask God?”
- Bad question: “Why did the disciples flee when Jesus was arrested?”
  - Rather, “What would be going through your mind if you witnessed the arrest?”



# Focus Attention on Target

- Will the question lead to the target (the main point of the lesson)?
- “Rabbit trails” should be brief & few
  - “This discussion is very interesting, but we need to get back to passage...”



# Guiding Questions

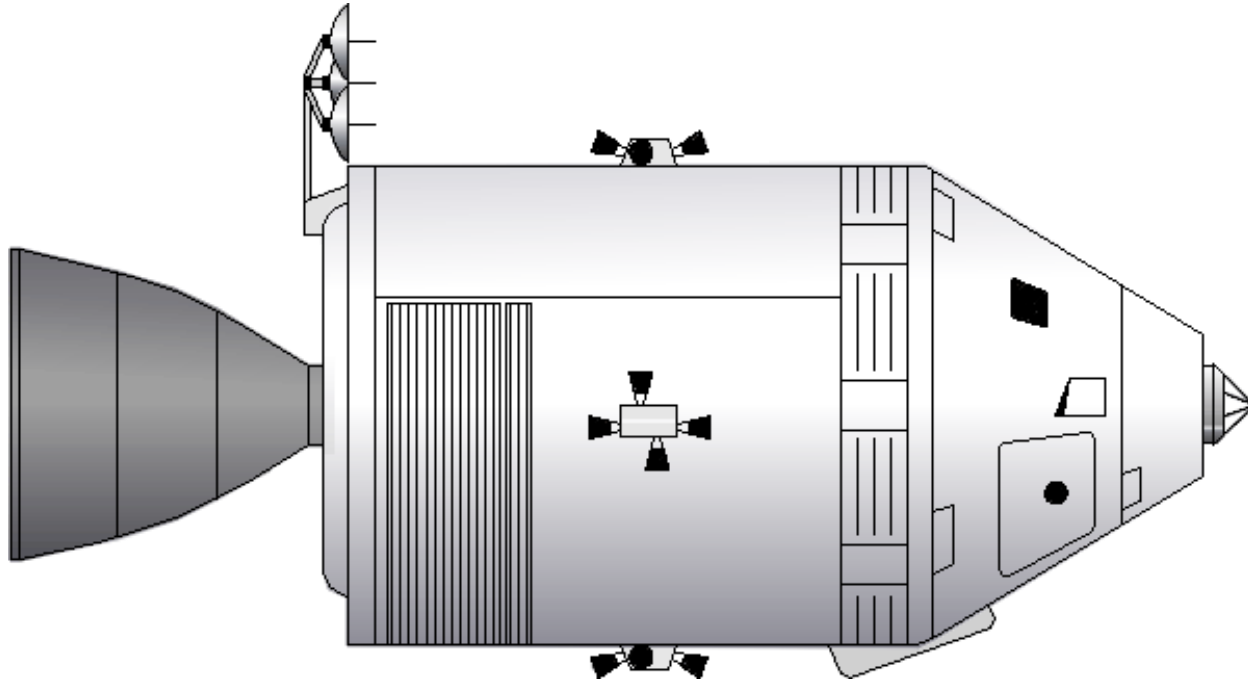

Directing Conversation to the Target

# Guiding Questions

**Emphasize** – *Why are we studying this?*

- “What are the benefits (or dangers) of turning the other cheek?”

**Relate** – *How does this relate to \_\_\_\_\_?*

- “How does the story of Joseph illustrate this? How did Jesus exemplify this?”

**Summarize** – *Based upon what we’ve seen so far, what principle is God’s Word teaching?*

- “We’ve seen many examples in Scripture of turning the other cheek; what are some other places in which the principle is taught?”

**Apply** – *How does this apply to our lives?*

- “What are some situations that you face where it is difficult to turn the other cheek?”

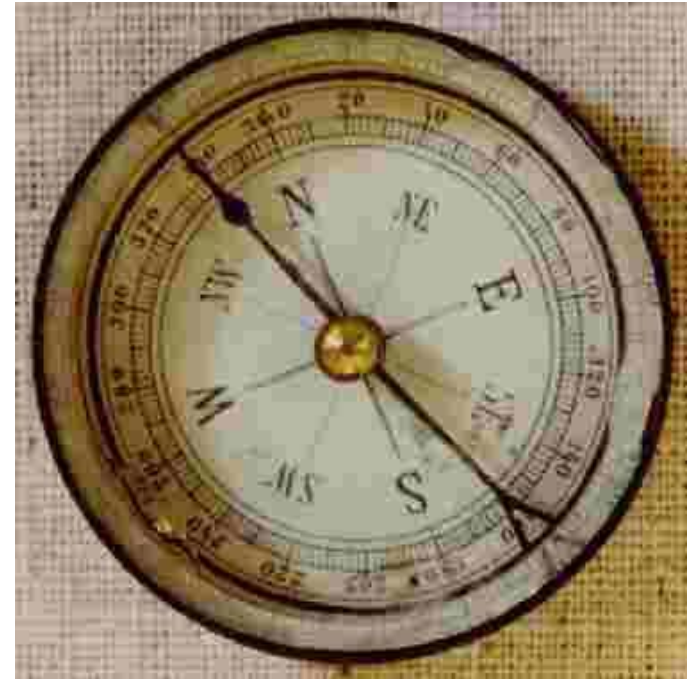

# Ways to Encourage Discussion

- Orchestrate – avoid too much “dead air”, but allow people time to think and respond
- Most launching questions need follow-up questions to keep discussion going
- Affirm responses whenever possible
  - “Very good!”
  - “That’s very insightful”
  - “I like the way you put that”
  - “That’s a good illustration of what we’ve been saying”
  - “Thank you for your openness and honesty”



# Responding to a Wrong Answer

- Was it wrong or just different?
- Redirect the question
  - “What do you think, Bob? Any other ideas?”
- Point back to Scripture
  - “Look at verse 15; what does it say?”
- Make a short presentation
  - The last resort



# Other Problems to Avoid

- Too much time spent on certain questions
- Conflict over disagreements
- Monopolizing of conversation

